

## MOTION click™

### 1. Introduction

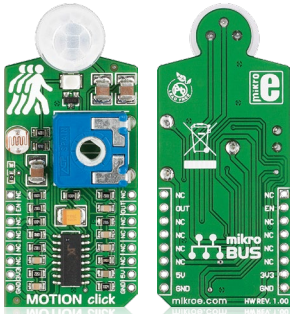

MOTION click™ is a simple solution for adding an infrared motion detector—sensitive only to live bodies—to your design. It carries a PIR500B Pyroelectric motion sensor connected to a BISS001 infrared sensor controller IC. Onboard potentiometer enables you to calibrate the sensor for distance. The board also features a photo resistor that enables you to set the sensor to work only at night. MOTION click™ communicates with the target board through **mikroBUS™** INT (out) and RST lines. It uses a 3.3V power supply.

### 2. Soldering the headers

Before using your click™ board, make sure to solder 1x8 male headers to both left and right side of the board. Two 1x8 male headers are included with the board in the package.

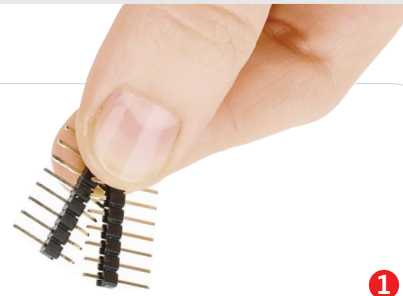

1

2

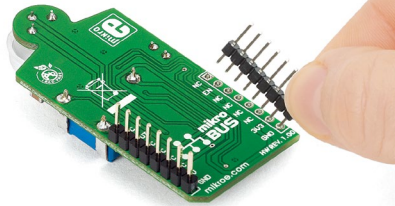

Turn the board upside down so that the bottom side is facing you upwards. Place shorter pins of the header into the appropriate soldering pads.

3

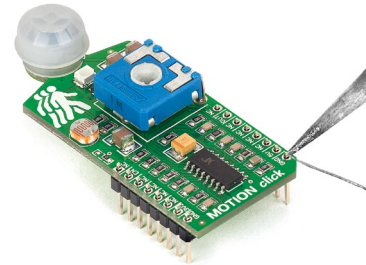

Turn the board upward again. Make sure to align the headers so that they are perpendicular to the board, then solder the pins carefully.

### 3. Plugging the board in

Once you have soldered the headers your board is ready to be placed into the desired mikroBUS™ socket. Make sure to align the cut in the lower-right part of the board with the markings on the silkscreen at the mikroBUS™ socket. If all the pins are aligned correctly, push the board all the way into the socket.

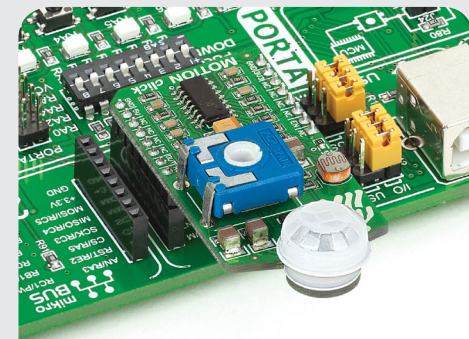
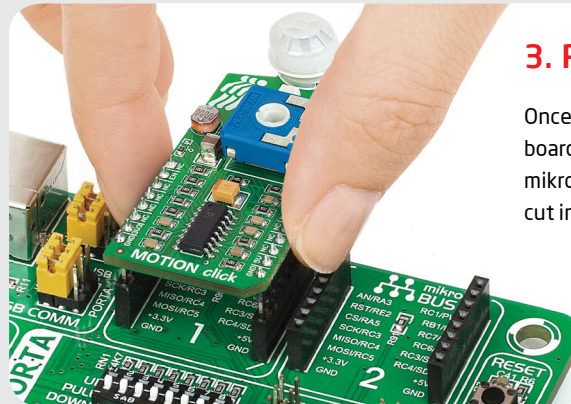

### 4. Essential features

MOTION click™ is ideal for alarm systems, light switch controllers, and similar systems where human presence needs to be detected. The pyroelectric motion sensor generates a voltage when exposed to infrared radiation emitted by live bodies (the white plastic Flesner lens covering the sensor filters visible light). The BISS001 IC processes the signal and sends an interrupt to the MCU. To set up the detecting range of the sensor (up to 4 meters), use the onboard potentiometer. You can also activate and deactivate the sensor through the mikroBUS™ RST pin.

click™  
BOARD  
[www.mikroe.com](http://www.mikroe.com)

MOTION click™ manual  
ver. 1.00



0 100000 026960

## 5. MOTION click™ board schematic

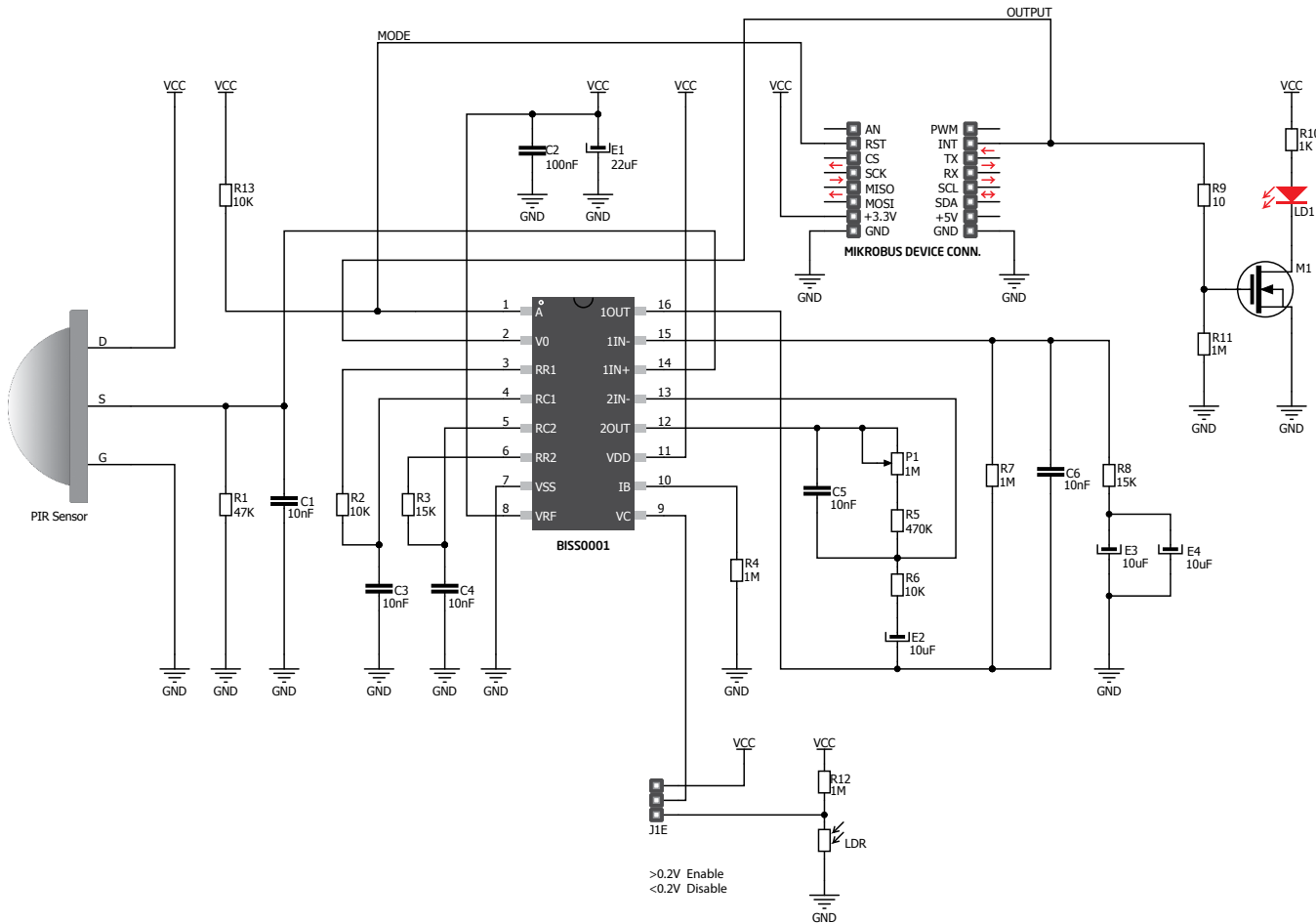

## 6. Photo resistor

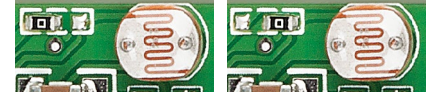

You can set up MOTION click™ to be operational only in darkness by activating the onboard Photo resistor. All you have to do is resolder the zero-ohm jumper just below the photo resistor on the left side of the click™ board.

## 7. Code examples

Once you have done all the necessary preparations, it's time to get your click™ board up and running. We have provided examples for mikroC™, mikroBasic™ and mikroPascal™ compilers on our **Libstock** website. Just download them and you are ready to start.



## 8. Support

MikroElektronika offers **free tech support** ([www.mikroe.com/support](http://www.mikroe.com/support)) until the end of the product's lifetime, so if something goes wrong, we're ready and willing to help!